



SELECTION CHART ACCORDING TO FLUOROCHROME CHARACTERISTICS

Fluorochrome	Excitation maximum (nm)	Emission maximum (nm)	Applicable mirror unit	Comment
Green Fluorescent Protein variants				
GFP (WT)	395, 475	510	U-MWIB2, U-MWIBA2, MNIBA2, U-MGFPHQ	
GFP (S65T)	488	510	U-MWIB2, U-MWIBA2, U-MNIBA2, U-MGFPHQ	
EGFP	488	507	U-MWIB2, U-MWIBA2, U-MNIBA2, U-MGFPHQ	
EBFP	380	440	U-MWU2, U-MNU2, U-MNUA2	
EYFP	513	527	U-MWIB2, U-MWIBA2, U-MNIBA2, U-MYFPHQ	
ECFP	433, 453	475, 501	U-MWBV2, U-MNBV2, U-MCFPHQ	
RFP (DsRed)	558	583	U-MWIG2, U-MWIY2	
Carbohydrate modification, protein modification (labeling)				
Fluorochrome antibody labeling				
Alexa Fluor 350	346	442	U-MWU2, U-MNU2, U-MNUA2	
Alexa Fluor 430	431	541	U-MWBV2, U-MNBV2	
Alexa Fluor 488	495	519	U-MWIB2, U-MWIBA2, U-MNIBA2	
Alexa Fluor 532	531	554	U-MWIB2, U-MWIBA2, U-MNIBA2	
Alexa Fluor 546	556	573	U-MWIG2	
Alexa Fluor 568	578	603	U-MWG2, U-MNG2, U-MWIG2	
Alexa Fluor 594	590	617	U-MWIY2	
Allophycocyanin (APC)	650	660	U-MWIY2	
7-amino-4-methylcoumarin-3-acetic acid (AMCA)	350	450	U-MWU2, U-MNU2, U-MNUA2	
BODIPY FL	503	512	U-MWIB2, U-MWIBA2, U-MNIBA2	
Cascade Blue	376	425	U-MWU2, U-MNU2, U-MNUA2	
Fluorescein-isothiocyanate (FITC)	490	520	U-MWIB2, U-MWIBA2, U-MNIBA2	
Oregon Green 488	496	520	U-MWIB2, U-MWIBA2, U-MNIBA2	
Phycoerythrin B (PE-B)	545	576	U-MWG2, U-MNG2, U-MWIG2	
Phycoerythrin R (PE-R)	490, 565	578	U-MWIG2, U-MNG2, U-MWIB2	
Rhodamine B-isothiocyanate (RITC)	570	595	U-MWG2, U-MNG2, U-MWIG2	
Texas Red	596	620	U-MWIY2	
Tetramethylrhodamine-isothiocyanate (TRITC)	541	572	U-MWIG2	
LaserPro IR 790	785	800	*1	
Protein modification				
8-Anilino-1-naphthalene sulfonic acid Mg salt (ANS)	385	485	U-MWU2, U-MNU2, U-MNV2	Hydrophobic domain
Coumarin maleimide (CPM)	385	465	U-MWU2, U-MNU2	Thiol group
Cy2	489	506	U-MWIB2, U-MWIBA2, U-MNIBA2	Amino group, antibody labeling
Cy3	552	565	U-MWIG2	Amino group, antibody labeling
Cy 3.5	581	596	U-MWIY2	Amino group, antibody labeling
Cy 5	650	667	U-MWIY2	Amino group, antibody labeling
Cy 5.5	675	694	*1	Amino group, antibody labeling
Cy 7	743	767	*1	Amino group, antibody labeling
Dimethylaminonaphthalene-5-sulfonic acid (DANS)	380	520	U-MWU2, U-MNU2	Thiol group
Dansyl chloraide	335	500	U-MWU2, U-MNU2	Amine labeling
Dansyl hydrazine	336	531	U-MWU2, U-MNU2	Carbonyl group
Eosin-isothiocyanate	524	548	U-MWIB2, U-MWIBA2, U-MNIBA2	Amine labeling
Fluorescamine	390	460	U-MWU2, U-MNU2, U-MNV2	Amine labeling
FluorX	494	520	U-MWIB2, U-MWIBA2, U-MNIBA2	Amino group, antibody labeling
Lucifer Yellow CH	435	530	U-MWBV2, U-MNBV2, U-MWB2	Aldehyde, Ketone
Monochlorobimane	380	461	U-MWU2, U-MNU2, U-MNUA2	Thiol group

Fluorochrome	Excitation maximum (nm)	Emission maximum (nm)	Applicable mirror unit	Comment
Protein modification				
o-Phtalaldehyde (OPT)	340	455	U-MWU2, U-MNU2, U-MNUA2	Amine labeling
Resorufin	570	585	U-MWG2, U-MNG2, U-MWIG2	Thiol group
SITS	350	420	U-MWU2, U-MNU2, U-MNUA2	Amine labeling
Carbohydrate modification				
Acriflavine SO2-PAS	430	515	U-MWBV2, U-MNBV2	Sugar
Nuclei, nucleic acid staining				
Nuclei, nucleic acid				
Acridine Orange	490	530, 640	U-MWB2, U-MNB2	Single/double-stranded nucleic acid
Acridine Yellow	470	550	U-MWB2, U-MNB2	Nucleic acid
Acriflavine-Feulgen	430	515	U-MWBV2, U-MNBV2	DNA
Auramine O-Feulgen	460	550	U-MWB2, U-MNB2	DNA
7-Amino Actinomycin D	555	655	U-MWIY2, U-MWIG2	Probe for G-C rich regions
bis-Aminophenyl-oxadizole (BAO) -Feulgen	380	470	U-MWU2, U-MNU2, U-MNUA2	DNA
BOBO 1	462	481	U-MWBV2, U-MNBV2, U-MWB2	DNA
BO PRO 1	462	481	U-MWBV2, U-MNBV2, U-MWB2	
Chromomycin A3	450	570	U-MWB2, U-MNB2, U-MWIB2	Probe for G-C rich regions
4, 6-diamidino-2-phenyl-indole HCl (DAPI)	372	456	U-MWU2, U-MNU2, U-MNUA2	Probe for A-T rich regions
Ethidium Bromide	545	605	U-MWG2, U-MNG2, U-MWIG2	DNA/RNA
Hoechst 33258	365	465	U-MWU2, U-MNU2, U-MNUA2	Probe for A-T rich regions
Hoechst 33342	355	465	U-MWU2, U-MNU2, U-MNUA2	Probe for A-T rich regions
Mithramycin	395	570	U-MWBV2, U-MNBV2	Probe for G-C rich regions
Olivomycin	430	545	U-MWBV2, U-MNBV2	Probe for G-C rich regions
Pararosaniline-Feulgen	560	625	U-MWG2, U-MNG2, U-MWIG2	DNA
POPO 1	434	456	U-MWBV2, U-MNBV2	
Propidium Iodide (PI)	530	615	U-MWG2, U-MNG2, U-MWIG2	DNA/RNA
Pyronin Y	540	570	U-MWIG2	DNA/RNA
Quinacrine Mustard	385	525	U-MWBV2, U-MNBV2	Probe for A-T rich regions, Q band
SYTOX Green nucleic acid stain	504	523	U-MWIB2, U-MWIBA2, U-MNIBA2	
Thiazole Orange	509	533	*1	
TOTO 1	514	533	*1	DNA
TOTO 3	642	661	*1	
TO PRO 3	642	661	*1	
YO PRO 1	491	509	U-MWIB2, U-MWIBA2, U-MNIBA2	
YOYO 1	490	510	U-MWIB2, U-MWIBA2, U-MNIBA2	DNA
Cell viability judgement				
Living cell staining				
Acridine Orange	490	590	U-MWB2, U-MNB2, U-MSWB2	Acid organelle
BCECF/AM	500	530	U-MWIB2, U-MWIBA2, U-MNIBA2	Esterase substrates
Calcein/AM	495	520	U-MWIB2, U-MWIBA2, U-MNIBA2	Esterase substrates
Carboxyfluorescein-diacetate (CFDA)	495	520	U-MWIB2, U-MWIBA2, U-MNIBA2	Esterase substrates
Fluoresceindiacetate (FDA)	495	520	U-MWIB2, U-MWIBA2, U-MNIBA2	Esterase substrates
Dead cell staining				
Ethidium Bromide	545	605	U-MWG2, U-MNG2, U-MWIG2	Cell membrane impermeability
Ethidium homodimer-1	528	617	U-MWG2, U-MNG2, U-MWIG2	Cell membrane impermeability
Propidium Iodide (PI)	530	615	U-MWG2, U-MNG2, U-MWIG2	Cell membrane impermeability

Fluorochrome	Excitation maximum (nm)	Emission maximum (nm)	Applicable mirror unit	Comment
Membranes, organelle, membrane potential				
Membranes				
8-Anilino-naphthalene sulfonic acid (ANS)	385	485	U-MNV2	Marker for negatively loaded domain
Dil	550	565	U-MWG2, U-MNG2, U-MWIG2	Marker for positively loaded domain, tracer
DiO	484	501	U-MWB2, U-MNB2, U-MWIB2	Marker for positively loaded domain, tracer
Diphenylhexatriene (DPH)	351	430	U-MWU2, U-MNU2, U-MNUA2	Neutral
Filipin	350	—	U-MWU2, U-MNU2, U-MNUA2	Cholesterol
Fluorescamine	390	460	U-MWU2, U-MNU2, U-MNV2	Membrane surface protein
Merocyanine 540	500	572	U-MWG2, U-MNG2, U-MWIG2	Voltage sensitive dye
Organelle				
Acridine Orange	490	590	U-MWB2, U-MNB2, U-MWIB2	Lysosome, nucleus
BODIPY FL Ceramide	503	512	U-MWIB2, U-MWIBA2, U-MNIBA2	Golgi apparatus
DiO C6(3)	480	501	U-MWIB2, U-MWIBA2, U-MNIBA2	Endoplasmic reticulum
ERTracker Blue-White DPX	374	575	U-MWU2, U-MNU2, U-MNV2	Endoplasmic reticulum
JC-1	514	529	U-MWIB2, U-MWIBA2, U-MNIBA2	Mitochondria
LysoTracker Red DND-99	577	590	U-MWIG2, U-MWIY2	Lysosome
MitoFluor Green	489	517	U-MWIB2, U-MWIBA2, U-MNIBA2	Mitochondria
MitoTracker Red CMXRos	578	599	U-MWIG2, U-MWIY2	Mitochondria
Nile Red	485-530	525-605	U-MWB2, U-MNB2, U-MWIB2	Lysosome
Rhodamine 123	500	540	U-MWIB2, U-MWIBA2, U-MNIBA2	Mitochondria
Pyronin Y	540	570	U-MWIG2	Mitochondria
Membrane potential				
Di-4-ANEPPS	440/505	705	*1	Ratio metric
Di-8-ANEPPS	436/546	713	*1	Ratio metric
FM 1-43	488	520	*1	Synaptic vesicle
RH160	577	>610	*1	
RH414	520	>610	*1	
RH421	541	>590	*1	
RH423	520-550	>610	*1	
RH795	560	650	*1	
WW781	633	>645	*1	
Bacteria staining, bone staining				
Bacteria				
Acridine Orange	490	530, 640	U-MWB2, U-MNB2, U-MWIB2	Myobacterium tuberculosis
Acridine Yellow	470	550	U-MWB2, U-MNB2, U-MWIB2	Myobacterium tuberculosis, acid-fast bacteria
Auramine O	460	550	U-MWB2, U-MNB2, U-MWIB2	Myobacterium tuberculosis, acid-fast bacteria
Berberine sulfate	430	550	U-MWBV2, U-MNBV2	General bacteria
Coriphosphine O	460	575	U-MWB2, U-MNB2, U-MWIB2	Bacterial cell wall
Hoechst 33258	365	465	U-MWU2, U-MNU2, U-MNUA2	Mycoplasma detection
Bone				
Acidic Fuchsin (Pararosaniline)	540	630	U-MWG2, U-MNG2, U-MWIG2	Calcification
Calcein	495	520	U-MWB2, U-MNB2, U-MWIB2	Bone growth
Calcein Blue	375	435	U-MWU2, U-MNU2, U-MNUA2	Bone growth
Tetracycline	390	560	U-MWBV2, U-MNBV2, U-MWU2	Calcification
Xylenol Orange	440, 570	610	U-MWG2, U-MNG2, U-MWIG2	Bone growth

Fluorochrome	Excitation maximum (nm)	Emission maximum (nm)	Applicable mirror unit	Comment
Ion concentrations				
Calcium				
bis-Fura-2	340/380	510	*1	2-wavelength excitation
BTC	400/480	540	*1	2-wavelength excitation
Calcium Green	505	532	*1	1-wavelength
Fluo 3	485	503	*1	1-wavelength
Fura-2	340/380	510	*1	2-wavelength excitation
Indo-1	350	405/480	*1	2-wavelength emission
Oregon Green 488 BAPTA-1	497	517	*1	1-wavelength
Oregon Green 488 BAPTA-5N	497	517	*1	1-wavelength
pH				
BCECF	430/480	530	*1	2-wavelength excitation
Carboxy SNARF-1	530	580/630	*1	2-wavelength emission
Nerve cell tracer, others				
Nerve cell tracer				
Evans Blue	550	610	U-MWG2, U-MNG2, U-MWIG2	Retrograde labeling
Fast Blue	360	410	U-MWU2, U-MNU2, U-MNUA2	Retrograde labeling
Granular Blue	375	410	U-MWU2, U-MNU2, U-MNUA2	Retrograde labeling
True Blue	373	404	U-MWU2, U-MNU2, U-MNUA2	Retrograde labeling
Others				
Aniline blue			U-MWU2, U-MNU2, U-MNUA2	Cellulose
Alexa Fluor 488-Phalloidin	495	519	U-MWIB2, U-MWIBA2, U-MNIBA2	Actin fibers
Calcofluor white	440	500-520	U-MWU2, U-MNU2, U-MNV2	Cellulose
Euchrysin (Acridine Orange)			U-MWU2, U-MNU2, U-MNUA2	Cellulose
Lucifer Yellow CH	430	535	U-MWBV2, U-MNBV2	Tracer
NanoOrange	485	590	U-MWIG2, U-MWG2, U-MWIB2	Protein quantification
NBD-Phalloidin	465	530	U-MWIB2, U-MWIBA2, U-MNIBA2	Actin fibers
Primuline O	410	550	U-MWIG2, U-MWG2, U-MWIB2	Cellulose
Rhodamine-Phalloidin	550	580	U-MWG2, U-MNG2, U-MSWG2	Actin fibers
Spectrum Aqua	433	480	U-MWBV2, U-MNBV2	FISH probe labeling
Spectrum Gold			*1	FISH probe labeling
Spectrum Green	497	524	U-MWIB2, U-MWIBA2, U-MNIBA2	FISH probe labeling
Spectrum Orange	559	588	U-MWG2, U-MNG2, U-MWIG2	FISH probe labeling
sulforhodamine 101	586	605	U-MWIY2	Tracer
Thioflavin T	430	550	U-MWBV2, U-MNBV2	Amyloid

MIRROR UNIT DATA

Mirror unit	Excitation filter	Emission filter	Dichromatic mirror	Applicable fluorochrome
U-MWU2	330-385	420	400	4, 6-diamidino-2-phenyl-indole HCl (DAPI), 7-amino-4-methylcoumarin-3-acetic acid (AMCA), 8-Anilino-1-naphthalene sulfonic acid Mg salt (ANS), Alexa Fluor 350, Aniline blue, bis-Aminophenyl-oxadizole (BAO) -Feulgen, Calcein Blue, Calcofluor white, Cascade Blue, Coumarin maleimide (CPM), Diphenylhexatriene (DPH), Dansyl chloraide, Dansyl hydrazine, Dimethylaminonaphthalene-5-sulfonic acid (DANS), EBFP, ERTracker Blue-White DPX, Euchry sine (Acridine Orange), Fast Blue, Filipin, Fluorescamine, Granular Blue, Hoechst 33258, Hoechst 33342, Monochlorobimane, o-Phtalaldehyde (OPT), SITS, Tetracycline, True Blue
U-MNU2	360-370	420	400	4, 6-diamidino-2-phenyl-indole HCl (DAPI), 7-amino-4-methylcoumarin-3-acetic acid (AMCA), 8-Anilino-1-naphthalene sulfonic acid Mg salt (ANS), Alexa Fluor 350, Aniline blue, bis-Aminophenyl-oxadizole (BAO) -Feulgen, Calcein Blue, Calcofluor white, Cascade Blue, Coumarin maleimide (CPM), Dansyl chloraide, Dansyl hydrazine, Diphenylhexatriene (DPH), Dimethylaminonaphthalene-5-sulfonic acid (DANS), EBFP, ERTracker Blue-White DPX, Euchry sine (Acridine Orange), Fast Blue, Filipin, Fluorescamine, Granular Blue, Hoechst 33258, Hoechst 33342, Monochlorobimane, o-Phtalaldehyde (OPT), SITS, True Blue
U-MNV2	400-410	455	455	8-Anilino-1-naphthalene sulfonic acid Mg salt (ANS), Calcofluor white, ERTracker Blue-White DPX, Fluorescamine
U-MWBV2	400-440	475	455	Acriflavine SO2-PAS, Acridine Orange, Acriflavine-Feulgen, Alexa Fluor 430, Berberine sulfate, BOBO 1, BO PRO 1, ECFP, Lucifer Yellow CH, Mithramycin, Olivomycin, POPO 1, Quinacrine Mustard, Spectrum Aqua, Tetracycline, Thioflavin T
U-MNBV2	420-440	475	455	Acriflavine SO2-PAS, Acriflavine-Feulgen, Alexa Fluor 430, Berberine sulfate, BOBO 1, BO PRO 1, ECFP, Lucifer Yellow CH, Mithramycin, Olivomycin, POPO 1, Quinacrine Mustard, Spectrum Aqua, Tetracycline, Thioflavin T

Mirror unit	Excitation filter	Emission filter	Dichromatic mirror	Applicable fluorochrome
U-MWB2	460-490	520IF	500	Acridine Orange, Acridine Yellow, Auramine O, Auramine O-Feulgen, BOBO 1, BO PRO 1, Calcein, Chromomycin A3, Coriphosphine O, DiO, Lucifer Yellow CH, Nile Red
U-MNB2	470-490	520IF	500	Acridine Orange, Acridine Yellow, Auramine O, Auramine O-Feulgen, Calcein, Chromomycin A3, Coriphosphine O, DiO, Nile Red
U-MSWB2	420-440	475	455	Acridine Orange
U-MWIB2	460-490	510IF	505	Acridine Orange, Acridine Yellow, Alexa Fluor 488, Alexa Fluor 488-Phalloidin, Alexa Fluor 532, Auramine O, BCECF/AM, BODIPY FL, BODIPY FL Ceramide, Calcein, Calcein/AM, Carboxyfluorescein-diacetate (CFDA), Chromomycin A3, Coriphosphine O, Cy2, DiO, DiO C ₆ (3), EGFP, EYFP, Eosin-isothiocyanate, Fluoresceindiacetate (FDA), Fluorescein-isothiocyanate (FITC), FluorX, GFP (WT), GFP (S65T), JC-1, MitoFluor Green, NanoOrange, NBD-Phalloidin, Nile Red, Oregon Green 488, Phycoerythrin R (PE-R), Primuline O, Rhodamine 123, Spectrum Green, SYTOX Green nucleic acid stain, YO PRO 1, YOYO 1
U-MWG2	510-550	590	570	Acidic Fuchsin (Pararosaniline), Alexa Fluor 568, Dil, Ethidium Bromide, Ethidium homodimer-1, Evans Blue, Merocyanine 540, NanoOrange, Pararosaniline-Feulgen, Phycoerythrin B (PE-B), Primuline O, Resorufin, Rhodamine B-isothiocyanate (RITC), Rhodamine-Phalloidin, Spectrum Orange, Xylenol Orange
U-MNG2	530-550	590	570	Acidic Fuchsin (Pararosaniline), Alexa Fluor 568, Dil, Ethidium Bromide, Ethidium homodimer-1, Evans Blue, Merocyanine 540, Pararosaniline-Feulgen, Phycoerythrin B (PE-B), Phycoerythrin R (PE-R), Propidium Iodide (PI), Resorufin, Rhodamine B-isothiocyanate (RITC), Rhodamine-Phalloidin, Spectrum Orange, Xylenol Orange
U-MSWG2	480-550	590	570	Rhodamine-Phalloidin
U-MWIG2	520-550	580IF	565	7-Amino Actinomycin D, Acidic Fuchsin (Pararosaniline), Alexa Fluor 546, Alexa Fluor 568, Cy3, Dil, Ethidium Bromide, Ethidium homodimer-1, Evans Blue, LysoTracker Red DND-99, Merocyanine 540, MitoTracker Red CMXRos, NanoOrange, Pararosaniline-Feulgen, Phycoerythrin B (PE-B), Phycoerythrin R (PE-R), Primuline O, Propidium Iodide (PI), Pyronin Y, Resorufin, RFP (DsRed), Rhodamine B-isothiocyanate (RITC), Spectrum Orange, Tetramethylrhodamine-isothiocyanate (TRITC), Xylenol Orange

Mirror unit	Excitation filter	Emission filter	Dichromatic mirror	Applicable Fluorochrome
U-MWIY2	545-580	610IF	600	7-Amino Actinomycin D, Alexa Fluor 594, Allophycocyanin (APC), Cy 3.5, Cy 5, LysoTracker Red DND-99, MitoTracker Red CMXRos, RFP (DsRed), sulforhodamine 101, Texas Red
U-MNUA2	360-370	420-460	400	4, 6-diamidino-2-phenyl-indole HCl (DAPI), 7-amino-4-methylcoumarin-3-acetic acid (AMCA), Alexa Fluor 350, Aniline blue, bis-Aminophenyl-oxadizole (BAO) -Feulgen, Calcein Blue, Cascade Blue, Diphenylhexatriene (DPH), EBFP, Euchrysin (Acridine Orange), Fast Blue, Filipin, Granular Blue, Hoechst 33258, Hoechst 33342, Monochlorobimade o-Phtalaldehyde (OPT), SITS, True Blue
U-MWIBA2	460-490	510-550	505	Alexa Fluor 488, Alexa Fluor 488-Phalloidin, Alexa Fluor 532, BCECF/AM, BODIPY FL, BODIPY FL Ceramide, Calcein/AM, Carboxyfluorescein-diacetate (CFDA), Cy2, DiO C ₆ (3), EGFP, EYFP, Eosin-isothiocyanate, Fluoresceindiacetate (FDA), Fluorescein-isothiocyanate (FITC), FluorX, GFP (WT), GFP (S65T), JC-1, MitoFluor Green, NBD-Phalloidin, Oregon Green 488, Rhodamine 123, Spectrum Green, SYTOX Green nucleic acid stain, YO PRO 1, YOYO 1
U-MNIBA2	470-490	510-550	505	Alexa Fluor 488, Alexa Fluor 488-Phalloidin, Alexa Fluor 532, BCECF/AM, BODIPY FL, BODIPY FL Ceramide, Calcein/AM, Carboxyfluorescein-diacetate (CFDA), Cy2, DiO C ₆ (3), EGFP, EYFP, Eosin-isothiocyanate, Fluoresceindiacetate (FDA), Fluorescein-isothiocyanate (FITC), FluorX, GFP (WT), GFP (S65T), JC-1, MitoFluor Green, NBD-Phalloidin, Oregon Green 488, Rhodamine 123, Spectrum Green, SYTOX Green nucleic acid stain, YO PRO 1, YOYO 1
U-MGFPHQ	460-480HQ	495-540HQ	485	EGFP, GFP (WT), GFP(S65T)
U-MYFPHQ	490-500HQ	515-560HQ	505	EYFP
U-MCFPHQ	425-445HQ	460-510HQ	450	ECFP

CHARACTERISTICS OF MIRROR UNIT'S WAVELENGTH

Ultraviolet excitation (wideband) **U-MWU2**

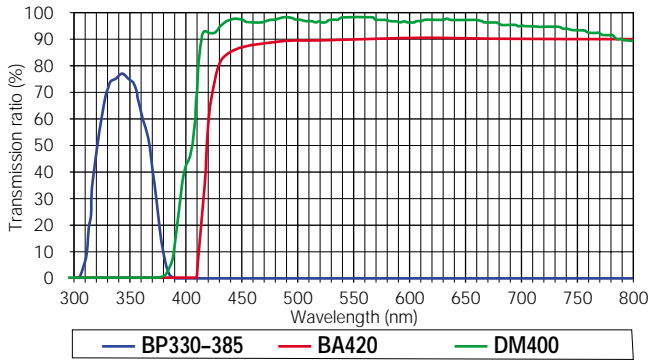

Blue excitation (narrow band) **U-MNBV2**

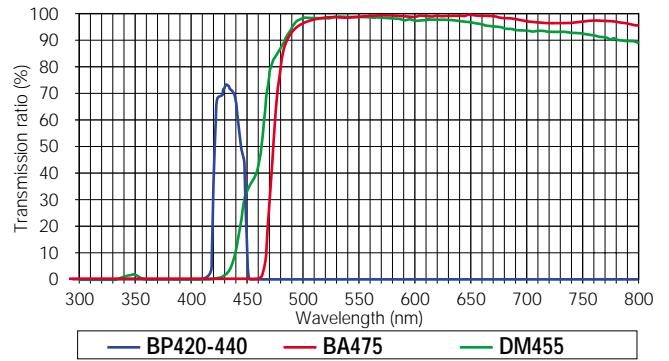

Ultraviolet excitation (narrow band) **U-MNU2**

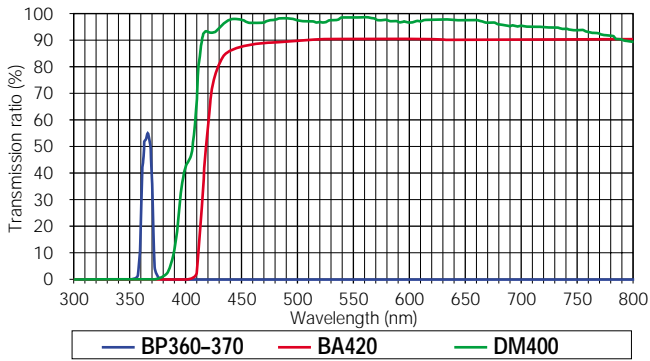

Blue excitation (super wideband) **U-MSWB2**

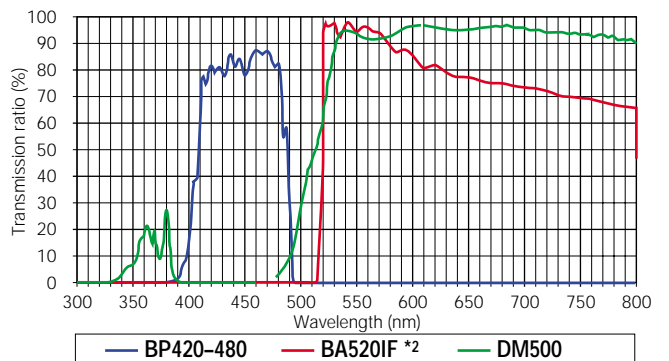

Violet excitation (narrow band) **U-MNV2**

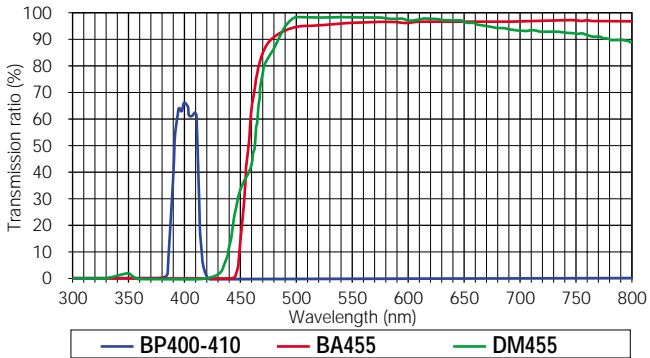

Blue excitation (wideband) **U-MWB2**

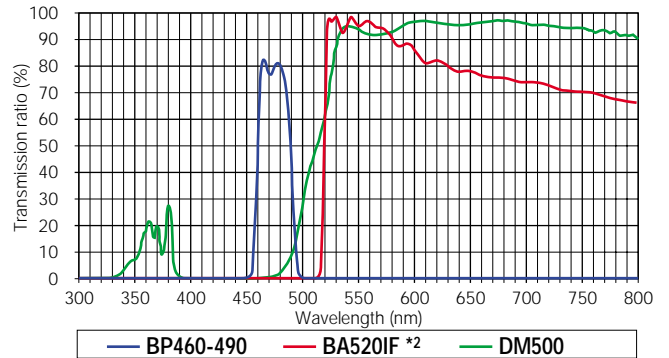

Blue excitation (wideband) **U-MWBV2**

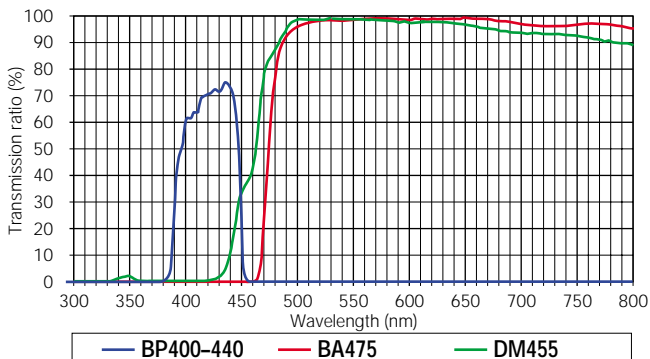

Blue excitation (narrow band) **U-MNB2**

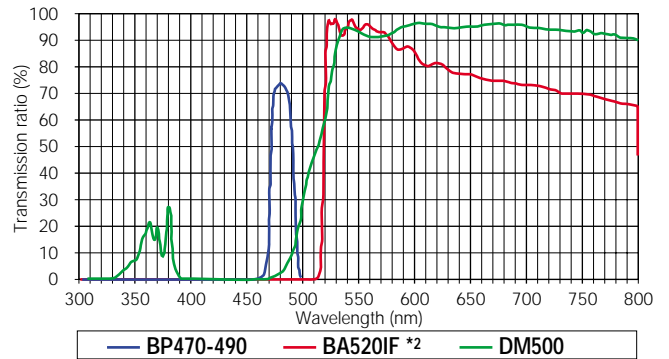

BP: Excitation filter BA: Barrier filter DM: Dichromatic mirror

Blue excitation (wideband)

U-MWIB2

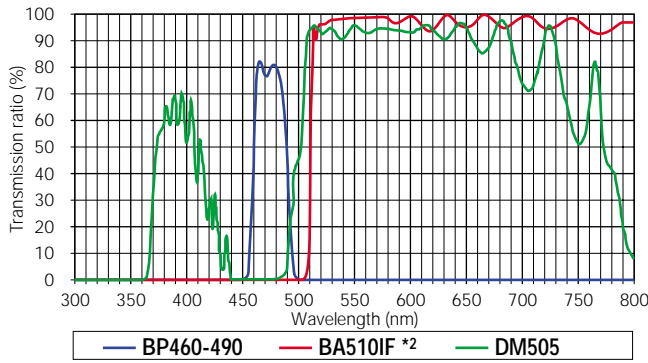

Green excitation (super wideband)

U-MSWG2

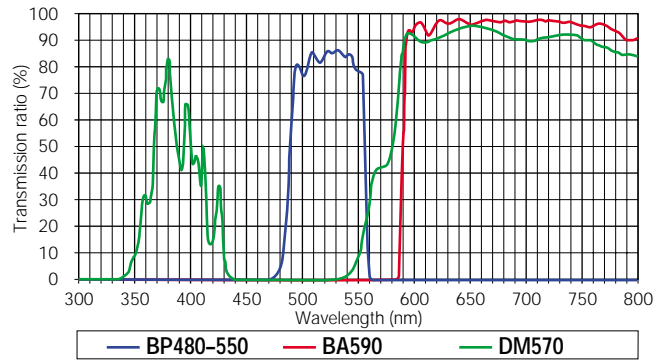

Blue excitation (narrow band)

U-MNIB2

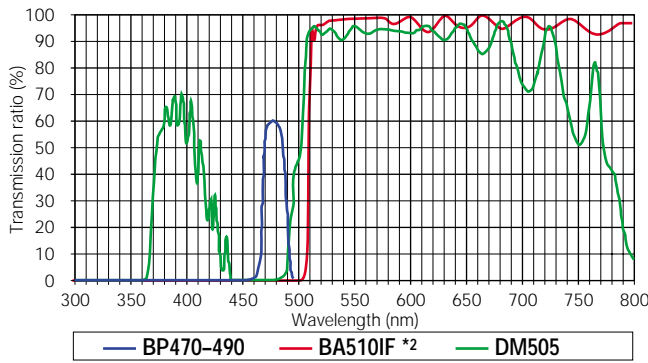

Green excitation (wideband)

U-MWIG2

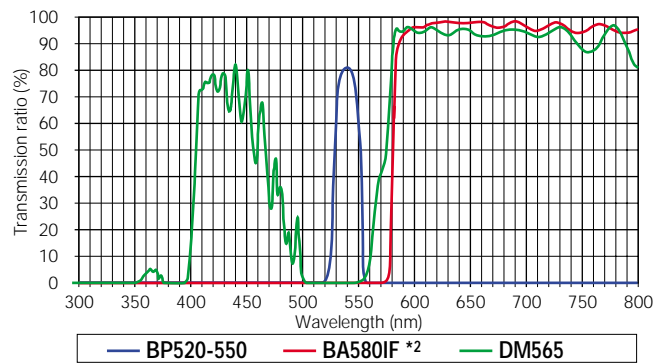

Green excitation (wideband)

U-MWG2

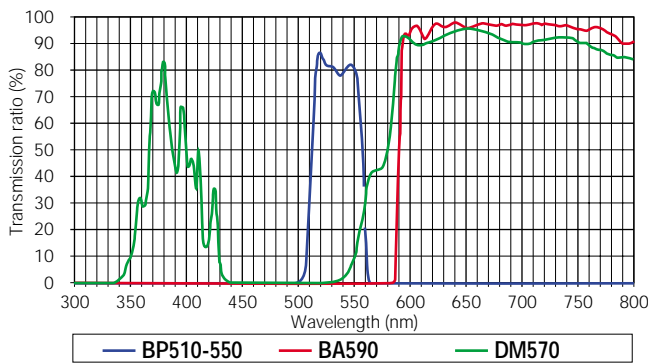

Green excitation (wideband)

U-MWIY2

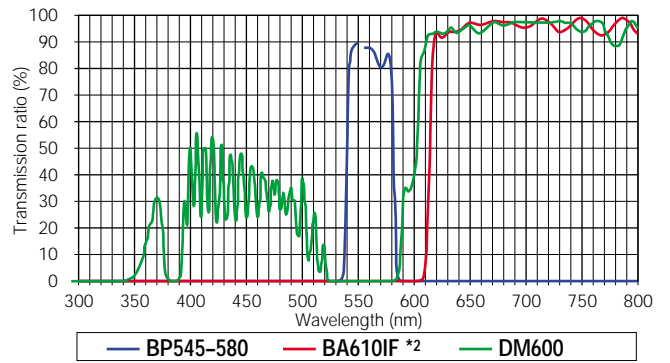

Green excitation (narrow band)

U-MNG2

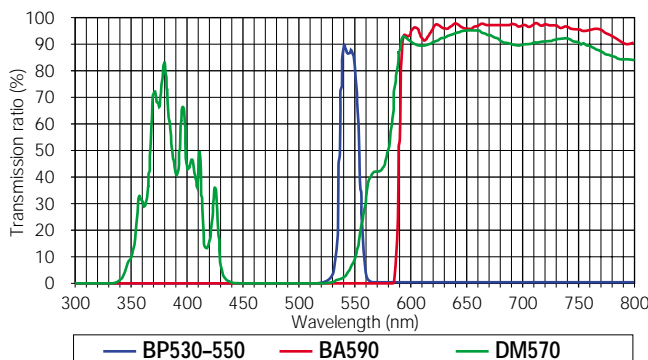

■ Band-pass Barrier Filter Type

Ultra violet excitation (narrow band)

U-MNUA2

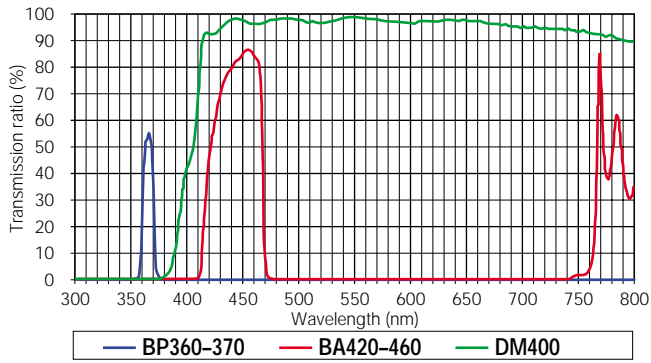

Blue excitation (wideband)

U-MWIBA2

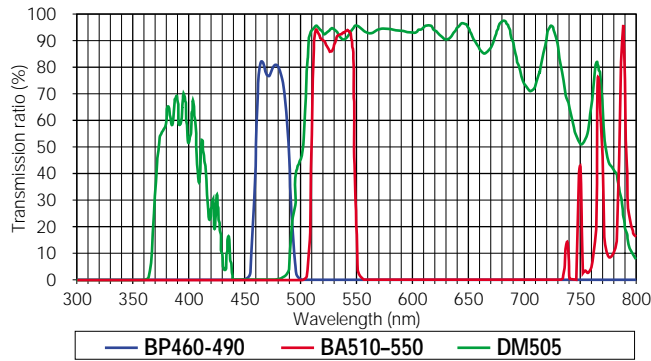

Blue excitation (narrow band)

U-MNIBA2

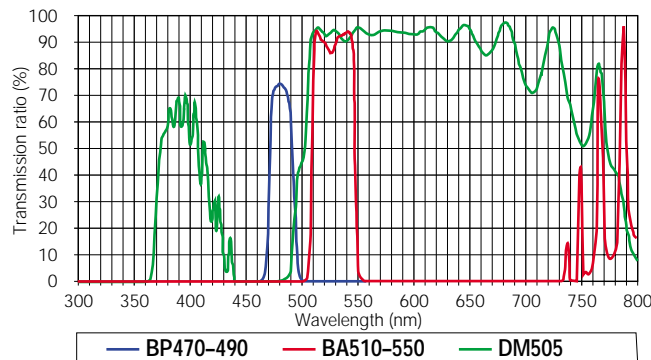

■ BX Macro Fluorescence Mirror Units

For GFP observation

U-MGFP/XL

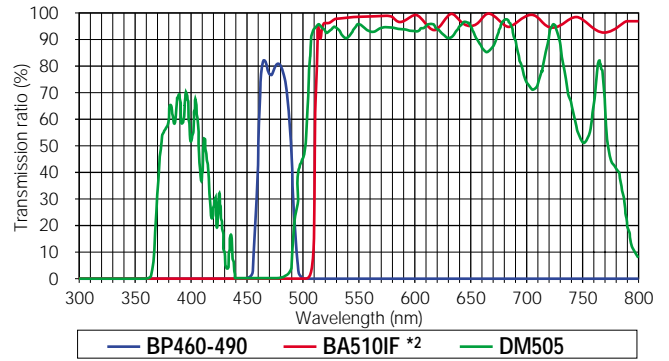

For GFP separation (Band-pass barrier filter)

U-MGFPA/XL

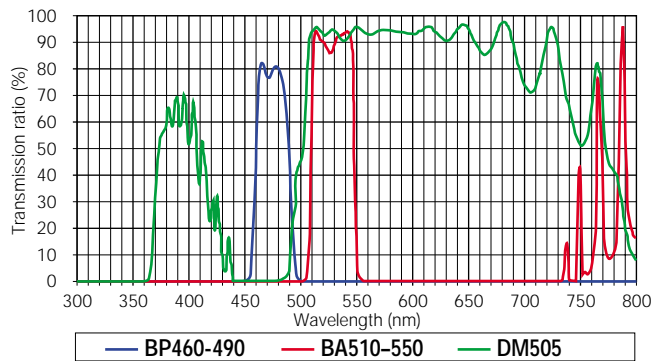

These two mirror units are needed to optimize illumination when using the XLFLUOR4X or XLFLUOR2X, which are low-magnification, macro fluorescence objectives. The dimensions of these mirror units are different from other Olympus mirror units.

■ CFP, GFP, YFP

for CFP

U-MCFPHQ

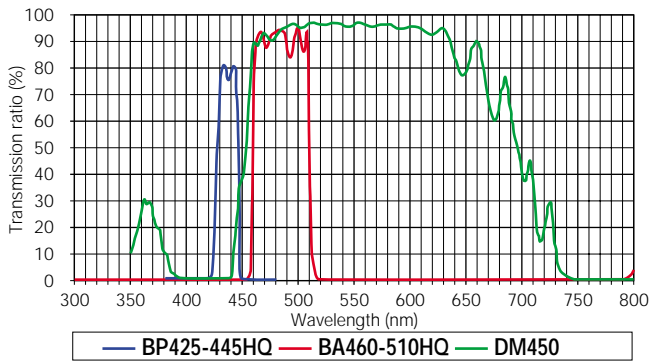

for GFP

U-MGFPHQ

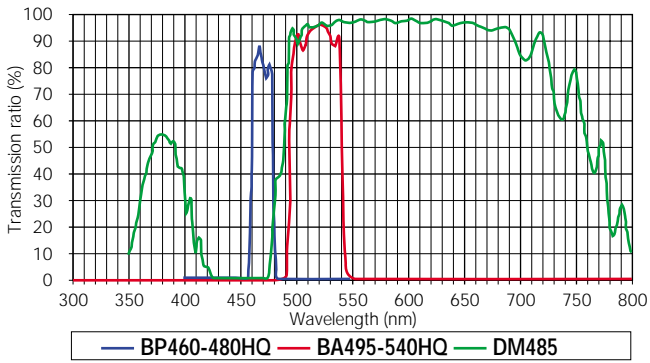

for YFP

UMYFPHQ

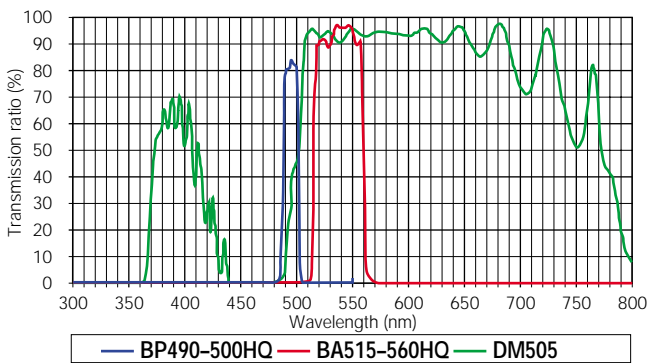

BP: Excitation filter BA: Barrier filter DM: Dichromatic mirror

These high-quality, purpose-designed filters with sharp cut-on/cut-off are manufactured using advanced ion deposition technology. This enables multiple (more than 100) very even layers, producing exceptionally sharp filter characteristics, compared to the maximum of around 50 layers which was possible using conventional vacuum deposition. In addition, the filter wavelength tolerance is below $\pm 2\text{nm}$, which is less than half of the conventional figure, and makes it possible to maximize fluorescence light transmission from the specimen. The use of a hard coating greatly improves performance problems caused by humidity.

■ Double Band

for DAPI/FITC

U-DM-DA/FI2 *3

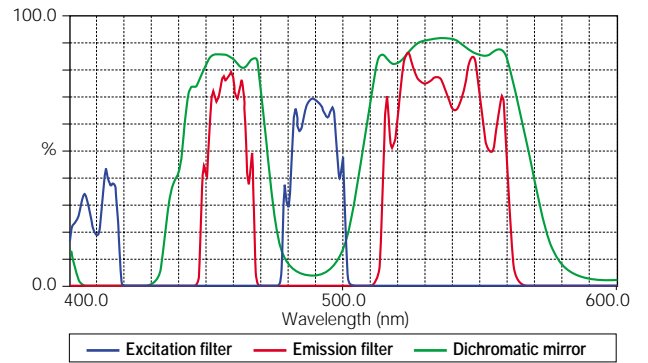

for DAPI/TRITC

U-DM-DA/TR2 *3

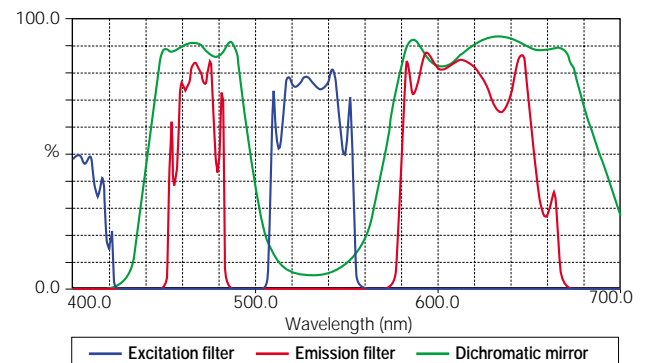

Can also be used for CFP/DsRed.

for DAPI/PI

U-DM-DA/PI2 *3

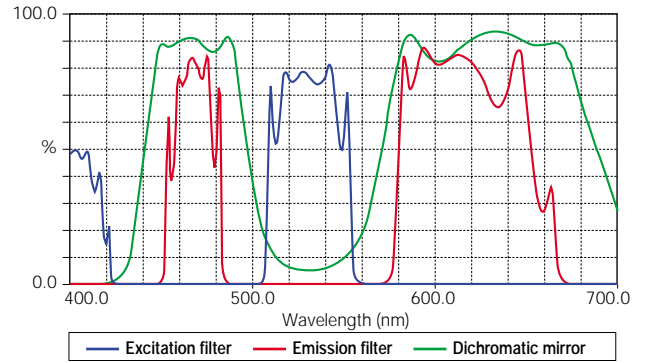

for DAPI/Texas Red

U-DM-DA/TX2 *3

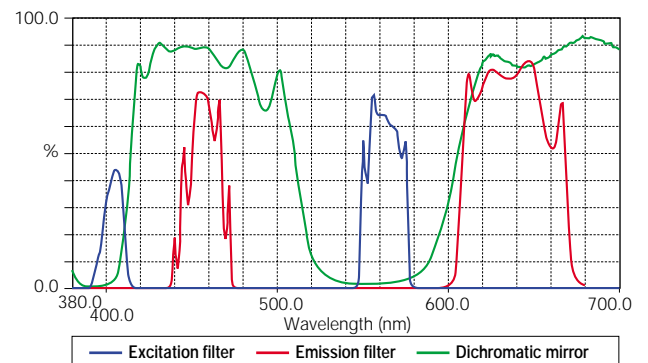

■ Triple Band

for FITC/TRITC

U-DM-FI/TR2 *3

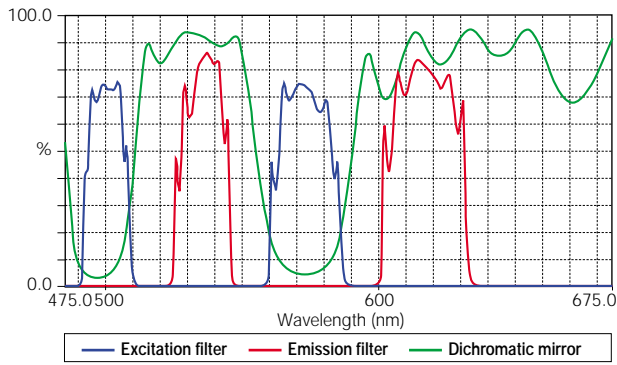

for DAPI/FITC/TRITC

U-DM-DA/FI/TR2 *3

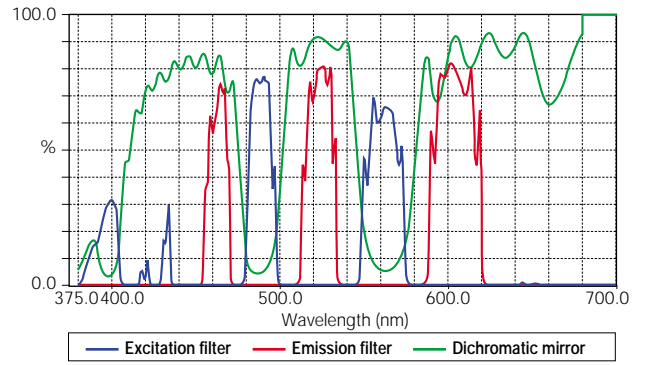

for FITC/Texas Red

U-DM-FI/TX2 *3

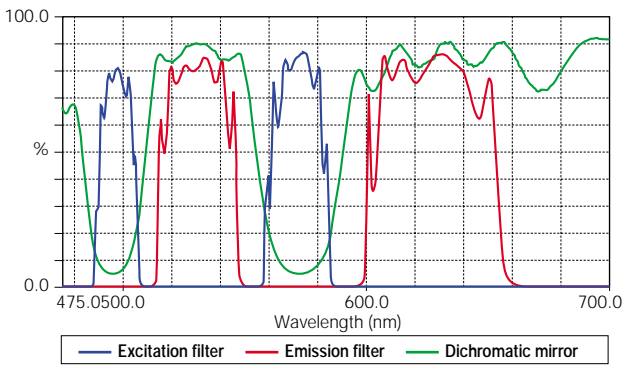

for DAPI/FITC/Texas Red

U-DM-DA/FI/TX2 *3

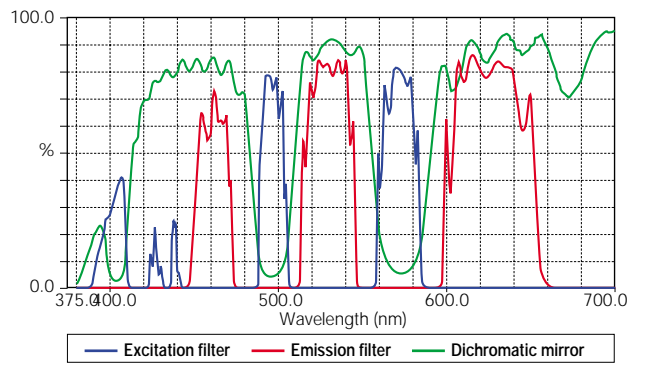

XF67 (for naked eye observation, with TX excitation),
XF56 (for CCD, eliminating infrared light)

for FITC/PI

U-DM-FI/PI2 *3

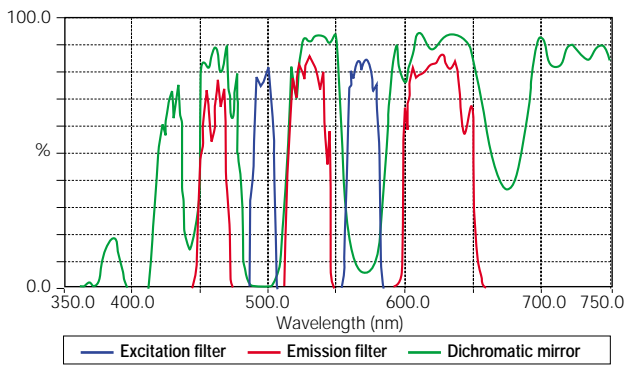

for DAPI/FITC/PI

U-DM-DA/FI/PI *3

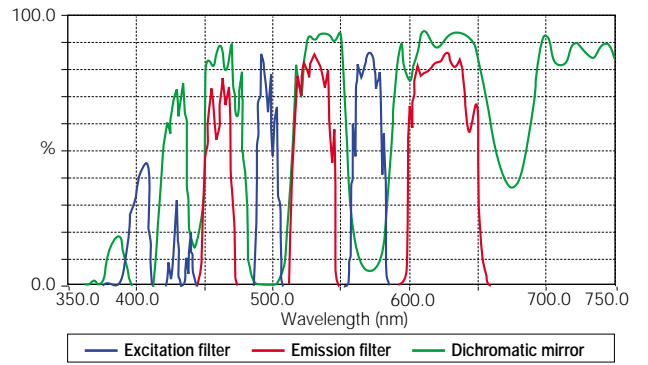

■ CY3/CY5/CY7

for CY3

U-DM-CY3 *3

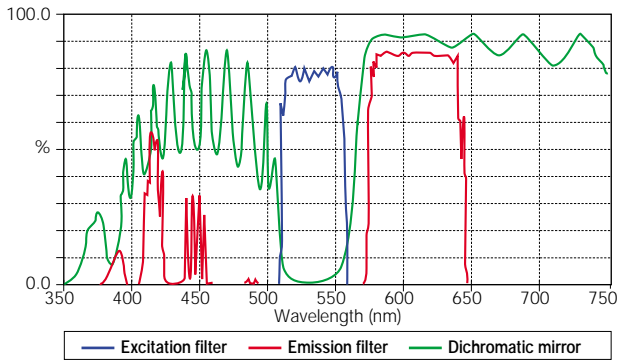

for CY5

U-DM-CY5 *3

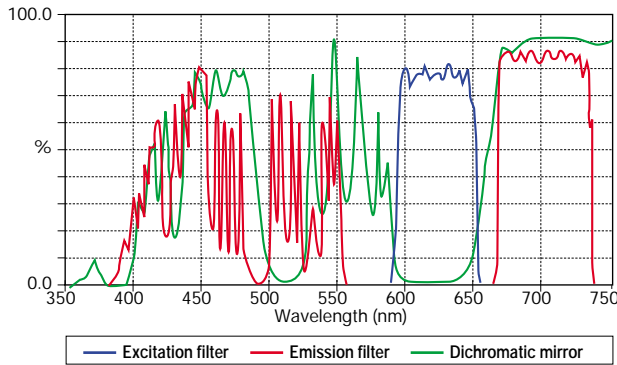

for CY7

U-DM-CY7 *3

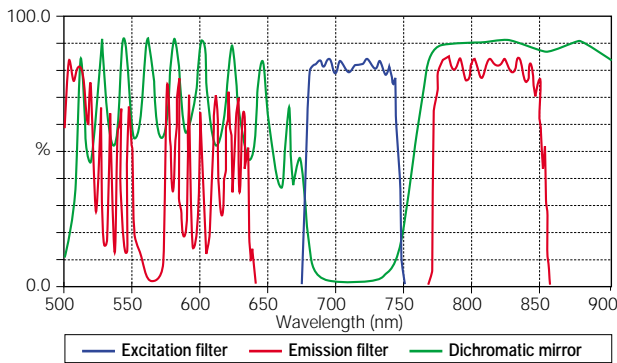

■ U-MF2: Empty Mirror Unit

1. U-MF2

The empty cube unit U-MF2 comes complete with filter fastening tools, so the user can attach/detach the filter frame. The empty cube can be disassembled using a small Phillips screwdriver, and a dichromatic mirror can be attached.



2. Assembling the fluorescence mirror unit

Custom fluorescence mirror units can be assembled by installing commercially available emission filters, excitation filters and dichromatic mirrors in the empty mirror unit (U-MF2).

■ Size requirement for optical parts

- Emission filter } $\varnothing 25 \pm 0.1$ mm, max. thickness 6mm
- Excitation filter }
- Dichromatic mirror } $26 \pm 0.1 \times 38 \pm 0.1$ mm, thickness 1 ± 0.05 mm

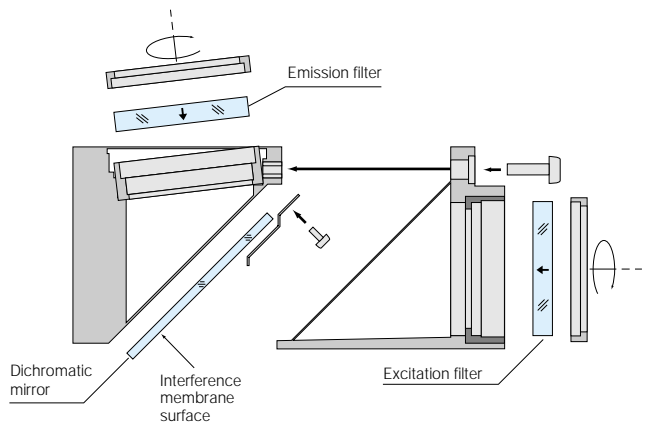

* When changing the dichromatic mirror, take care to avoid soiling the surface with finger marks, etc.

FLUORESCENCE EXCITATION BALANCERS

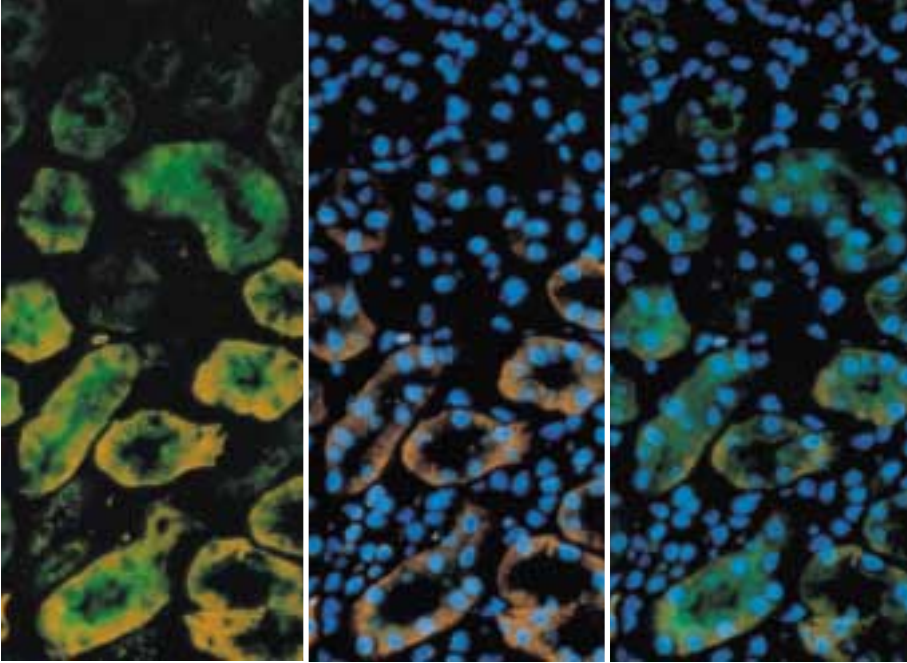

Triple labeled specimen with FITC and Cy3 enhanced

Triple labeled specimen with DAPI and Cy3 enhanced

Triple labeled specimen with balanced fluorescence representation

Excitation balancers are an exclusive Olympus accessory, available for most common dual or multi-label specimen. Used singly or in tandem, they curtail the individual excitation bandwidths of the fluorochromes under observation. This purposefully restricted excitation equalizes the emission intensities. Better differentiation of the multi-labels and better visibility of detail is achieved. This simple and visually controlled adjustment leads to perfect photomicrographs and digital images benefit from less severe post processing.

Excitation balancers are available for adjustment of the following fluorescence excitation pairs



Excitation balancer BG (U-EXBABG)

Blue/green, adjusting green and red emissions

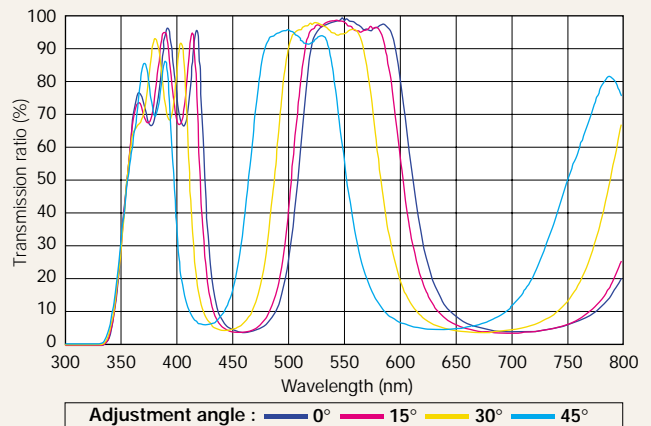

Excitation balancer UB (U-EXBAUB)

UV/blue, adjusting blue and green emissions

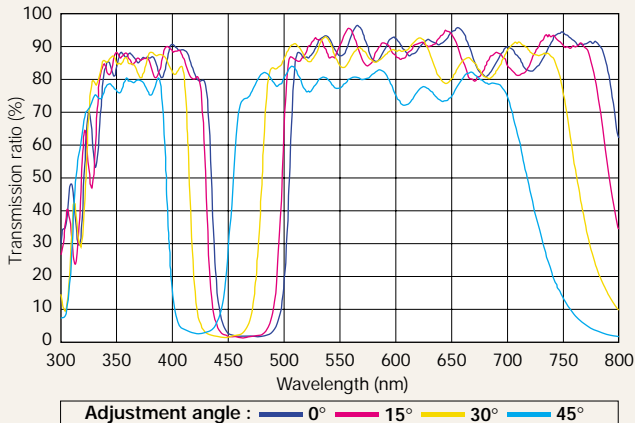

Excitation balancer UG (U-EXBAUG)

UV/green, adjusting blue and red emissions

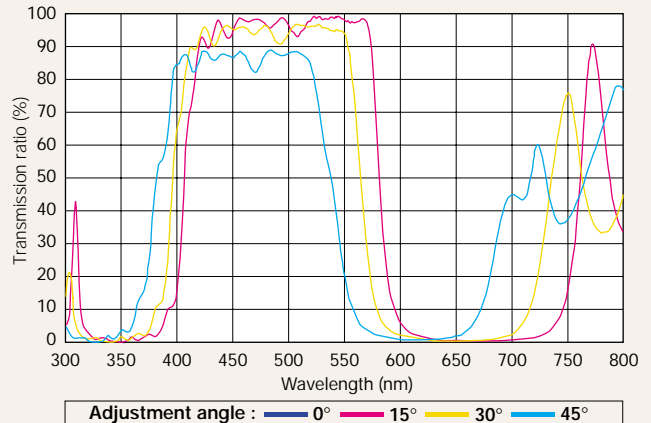

LIGHT SOURCE SPECTRAL CHARACTERISTICS

Mercury lamp

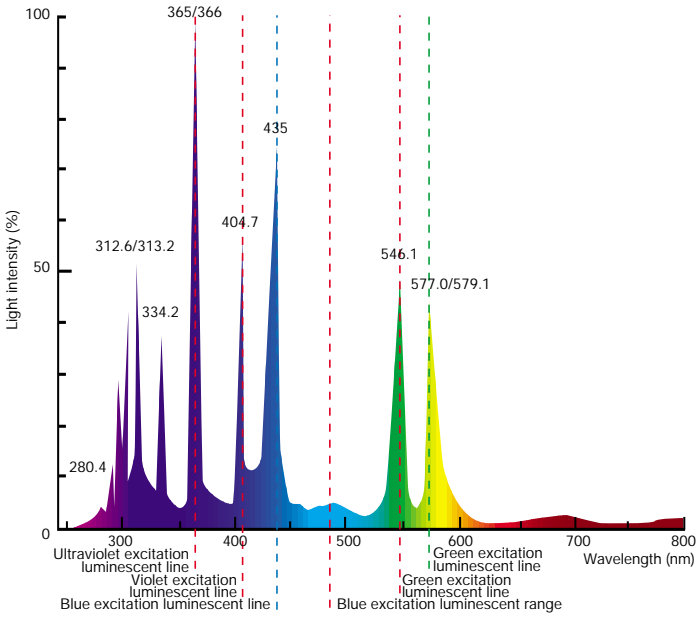

Xenon lamp

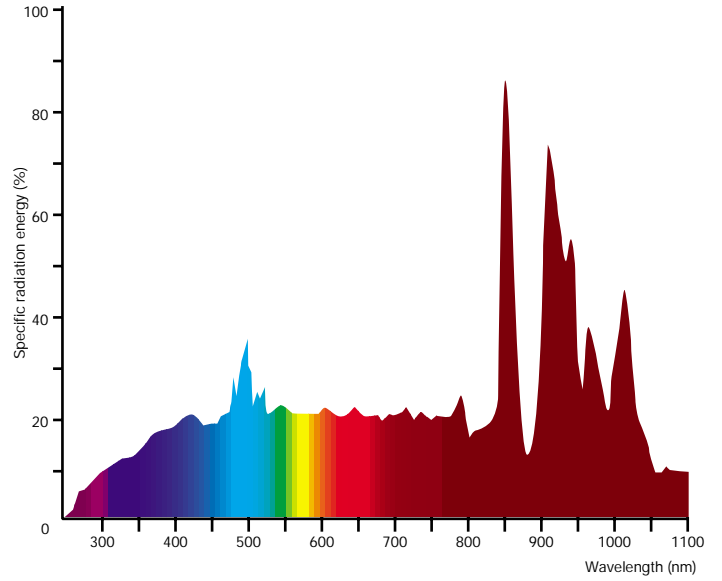

Metal halide lamp

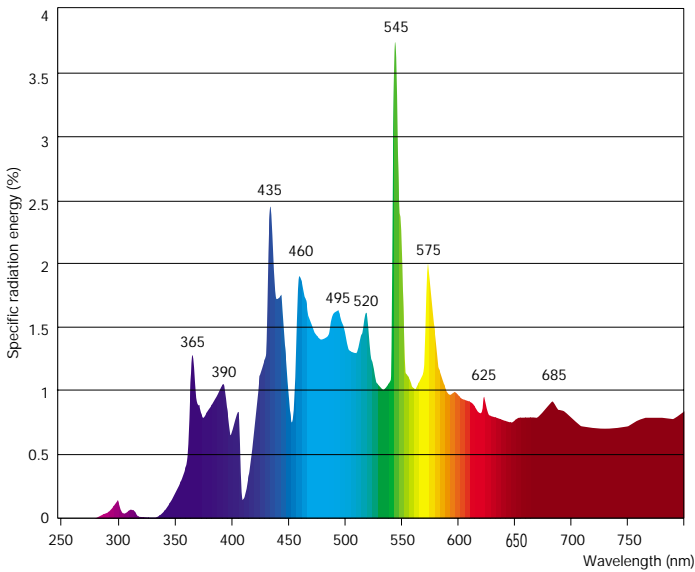

Halogen lamp

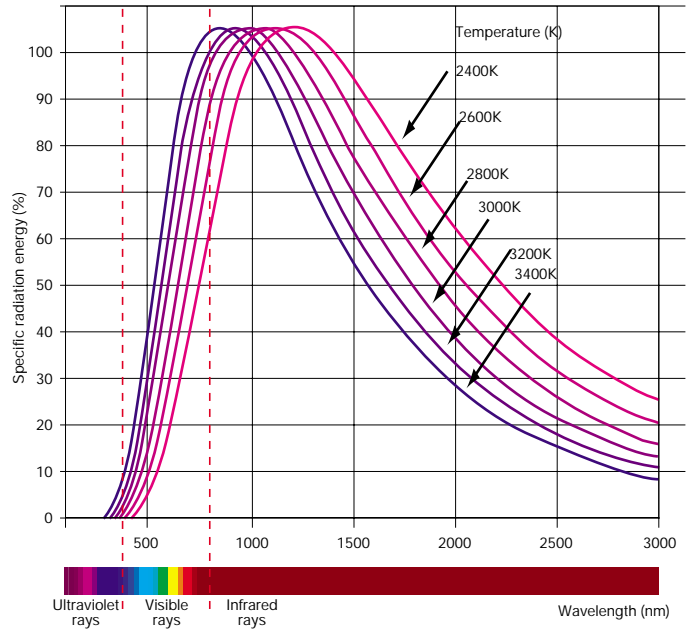

*1 Please contact your local sales representative for a specific filter combination.

*2 "IF" means high-performance interference type filter. It has a steep cutting edge, and excellent spitting characteristics.

*3 Please contact your local sales representative for additional information. These products are soft coated, therefore consumables.

Specifications are subject to change without any obligation on the part of the manufacturer.



OLYMPUS OPTICAL CO., LTD.
 San-Ei building, 22-2, Nishi Shinjuku 1-chome, Shinjuku-ku, Tokyo, Japan
OLYMPUS OPTICAL CO. (EUROPA) GMBH.
 Postfach 10 49 08, 20034, Hamburg, Germany
OLYMPUS AMERICA INC.
 2 Corporate Center Drive, Melville, NY 11747-3157, U.S.A.
OLYMPUS SINGAPORE PTE LTD.
 491B River Valley Road, #12-01/04 Valley Point Office Tower, Singapore 248373
OLYMPUS OPTICAL CO. (U.K.) LTD.
 2-8 Honduras Street, London EC1Y 0TX, United Kingdom.
OLYMPUS AUSTRALIA PTY. LTD.
 31 Gilbey Road, Mt. Waverley, VIC 3149, Melbourne, Australia.
OLYMPUS LATIN AMERICA, INC.
 6100 Blue Lagoon Drive, Suite 390 Miami, FL 33126-2087, U.S.A.

OLYMPUS BUSINESS AREAS

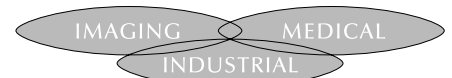

www.olympus.com